

Performance Analysis of Intersatellite Optical Wireless Communication (Isowc) Systems Using Mach-Zehnder Modulator and LiNbMech-Zehnder Modulator

Bandana mallick¹, G.Sagarika², Shital Patnayak³, Manas Ranjan Nilarout⁴

Associate Professor¹, Students^{2,3,4}, Dept. of Electronics & Communication Engineering,

GIET, Gunupur, Odisha, India

Email: pattnaikshital@gmail.com

Abstract- Isowc (Intersatellite Optical Wireless Communication) Has Been Evolved With Great Lot Of Improvement Which Overcomes Many Challenges And Issues That Had Been Gone Through During the use of Fibre Optical Communication Systems. It's An Already Known Fact That The Isowc Channels Provide Us With (A) Higher Bandwidth (B) Lower Size (C) Light Weight (D) Low Power Consumption (E) Low Cost, etc. In This Research, It is Amphasising On Designing Of 32-Channel Isowc And The Performance Characteristics Obtained From The Mz Modulator And LiNbMZ Modulator Separately With The Variation In Bit Rate From 5Gbps,7Gbps,9Gbps and 10gbps by considering the Q-factor. The intersatellite link was modeled and simulated using a commercial optical system simulator named optisystem (14.0) software by Optiwave. The simulation result shows that at lower bit rate MZ modulator provides better quality factor as compared to Li-Nb modulator. This thesis fully acknowledges about intersatellite communication link for future development of large data transfer with in different number of satellites (32-channels) with high Quality of Service (qos).

Index Terms- DWDM system ,MZ and LiNb modulator, Q-factor, eye diagram, BER analyzer, Bit error rate.

1. INTRODUCTION

The invention of Laser communication technology took in the year of 1962 and it was first used to communicate between a satellite and a submarine. With the flow of time, technological advancements have been witnessed [1]. The new technologies now being used are Microwave, OWC, IsOWC. Laser communication is now able to send information at data rates up to several Gbps and at distance of thousands of kilometers. However, the future technology of satellite to ground communication is going to be based upon microwave technology but satellite to satellite communication would regime on optical laser communication. As RF wavelength is much longer as

results lower loss as compared to RF. OWC technology has been used in several satellites as well such as European Space Agency (ESA's) Artemis in Japan's KIRARI satellite [2]. IsOWC system can construct high speed, large-capacity and low cost ISL links [3].Also its channel capacity is highly scalable allowing smooth up-gradation or transition from existing networks. . IsOWC frameworks give a high bandwidth, small size, small weight, low power and minimal effort different option for present microwave satellite frameworks. Basically a communication system include transmitter section, propagation section, receiving section. We have included PRBS, NRZ, CW laser, Modulators (MZ and LiNb-MZ) in transmitter section, OWC channel, amplifier gain,

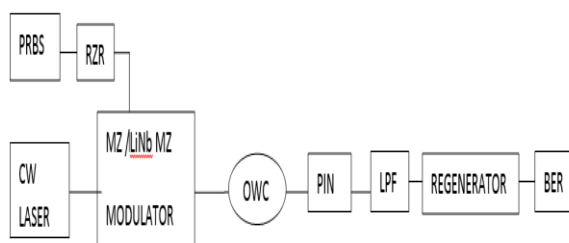

Fig. 1. Layout design of the inter-satellite communication system

compared to laser hence the beam width in laser is narrower than that of RF system so the OWClk

Links for propagation, PIN detector, Bessel's Low pass filter, 3R Generator, BER analyzer at receiver

section. Modulators are basically used for manipulate the intensity of beam i.e., to modulate the current driving the light source, e.g. a laser diode. This sort of modulation is called direct modulation, as opposed to the external modulation performed by a light modulator. For this reason light modulators with laser diodes where narrow line width is required, direct modulation is avoided due to a high bandwidth "chirping" effect when applying and removing the current to the laser. MZ (Mech-Zehnder) Modulators achieve better performance as compared to LiNb (Lithium-Niobate) Modulator as MZ achieves Zero-chirping condition as compared to LiNb MZ modulator. The Optical wireless communication

satellite which ensures that the connected satellites are well aligned and the space is considered to be vacuum. The advantages of using optical link over radio frequency (RF) links is the ability to send high speed data to a distance of thousands of kilometers using small size pay-load. By reducing the size of the payload, the mass and the cost of the satellite will also be decreases. Another reason of using optical wireless communications is due to wavelength. RF wavelength this much longer compared to lasers hence the beam width that can be achieved using lasers is narrower than that of the RF system. Due to this reason, Optical wireless communications link results in lower loss

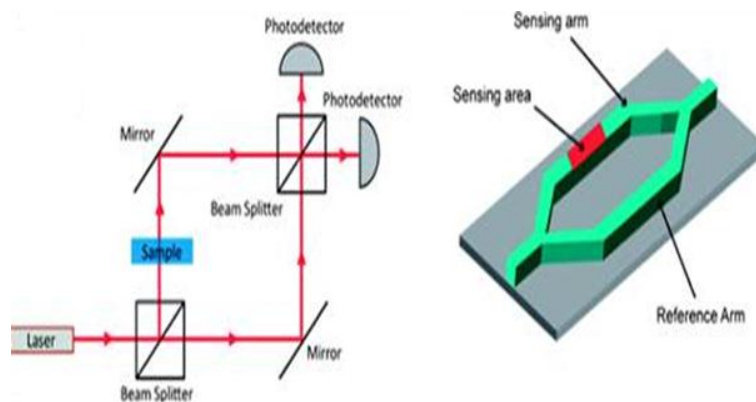

Fig. 2. MZ modulator inner view

systems are based on the basic principle of data transmission through air and using light as the carrier. The signal carrying information is being modulated on a laser which acts as a light source and is transmitted to another satellite in the free space. On the receiver side, this light signal is detected using a photo detector and then converted back into electrical signal.

compared to RF [4]. IsOWC proves to be a better alternative for transmission of data at high rates but various parameters need to be taken into account which degrades the system performance the pointing errors can arise due to mechanical misalignment, errors in tracking systems or due to mechanical vibrations present in the system. Different type of

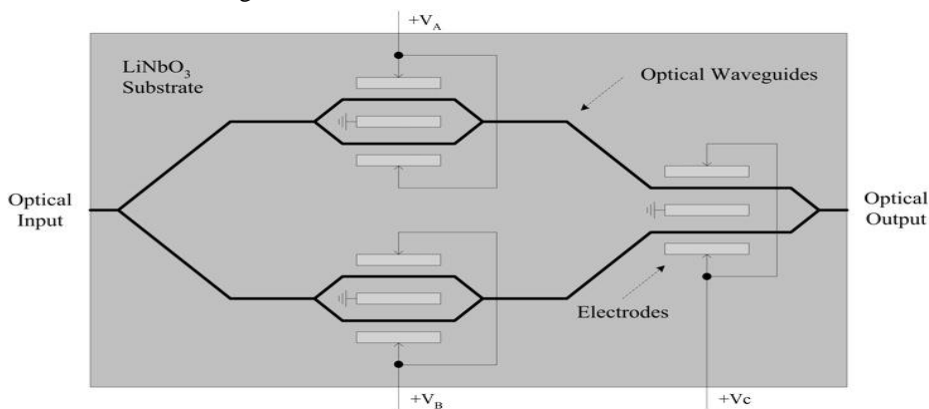

Fig. 3. LiNb MZ modulator

A highly accurate tracking system is required which involves the use of beacon signal on the one side and a quadrant detector with tracking system at other

modulators would also show variation in results. Modulators are basically used for manipulate the intensity of beam i.e., to modulate the current driving

the light source, e.g. a laser diode. This sort of modulation is called direct modulation, as opposed to the external modulation performed by a light modulator. For this reason light modulators, with laser diodes where narrow linewidth is required, direct modulation is avoided due to a high bandwidth "chirping" effect when applying and removing the current to the laser[5].MZ(Mech-Zehnder) Modulators achieve better performance as compared to LiNb(Lithium-Niobate) Moduater as MZ achieves Zero-chirping condition where as LiNb can't achieve the same as it includes different materials.

2. SYSTEM DESCRIPTION:

(a) Transmitter:

The IsOWC transmitter receives data from the satellites. Generally Lasers are used as light pulses. A light pulse is a light carrier having a unique wavelength generally measured in nanometers and symbolized as lambda. For transmission of data, a stream of digital data is transmitted over a physical layer device [6]

(b) MZ modulator:

MZ is an optical modulator that is used to vary intensity of the light source from the laser according to the output of the pulse generator. The Mach-Zehnder modulator consists of two couplers and two waveguides of equal-length. The input optical signal from the laser will split in to two parts and go through phase shifting process in the waveguides. Phase shifting happens due to the electro-optic effect where the output electrical pulse from the pulse generator will vary the voltage hence varying the refractive indices of the waveguides. The output of the Mach-Zehnder modulator will be transmitter to the other end through the space of OWC channel [7].

(c) LiNb:

LiNb (LiNbO3)/ Lithium Niobate is an electrooptic material. It is compact in size. It consumes low driving voltage and provides high data rate (upto 20-40 GHz).It also has good compatibility with optical fibers. It uses wafer fabrication, which is a light fabrication technology. But due to the materials fabricated it has some chirp.

(d) Chirp:

Chirp represents an unwanted phase shift which cause light pulses broadening and hence it limits the maximum frequency response of an optical link. This is minimum in MZ modulators when compared with LiNb MZ modulators.

(e) OWC (Optical wireless channel):

Optical wireless communication refers to transmission of optical data through wireless medium but the transmission takes place through unguided media. If the transmission of data is done between two satellites,

then the communication can be called as Inter satellite Optical Wireless Communication and the OWC channel being used here can be called as IsOWC channel. This implementation can be demonstrated using Optisystem software [8].

(f) Receiver:

For getting the exact desired output designing of receiver section is as crucial as transmitting section. For maximum efficiency and better results many errors have to be taken care of while modeling it .Bessel filter is the most commonly used filter in the receiver side due to its, linear phase response characteristics[9]. And this filter is free from ripples in pass band and possesses monotonic decay in stop band.

3. PROPOSED SYSTEM DESIGN:

We designed two models of Isowc link at varying operating frequency (193.0 to 196.0) by using different modulators.(i) By using a MZ modulator and (ii)By using a LiNb MZ modulator in order to compare the performance of each with respect to the Q-factor they provide at different bit rate and frequencies. The simulated models designed are similar to one another except the fact that the modulators used are different which consists of transmitter, propagating channel and receiver which is shown in fig.1 where the transmitter is in the first satellite and the receiver is in the second satellite. The owc channel being used here can be called as ISOWC channel(the term optical wireless refers to transmission of optical data through vaccum but the transmission takes place through unguided media)[10].In the optisystem software the owc channel is modeled between an Optical transmitter and Optical receiver with constant parameters like range=300km along with a loop control consisting of 2 number of loops, optical gain=30db, power=20db and variable parameters like frequency(193.0-196.0)nm ,bit rate(5Gbps,7Gbps,9Gbps,10Gbps).The system is designed based on the following parameter in table-1.

PARAMETERS	VALUES
Laser	CWL
Transmitting power	20dbm
Link range	600km
Data rate	5Gbps,7Gbps,9Gbps,10Gbps
Modulation	RZ
Optical efficiency	1
Aperture diameter transmitter and receiver	15cm
Additional losses	1db
Pointing errors	1.7 urad
Photo detector	PIN
Modulator	MZ/LiNb MZ

Table 1:Simulation Parameters.

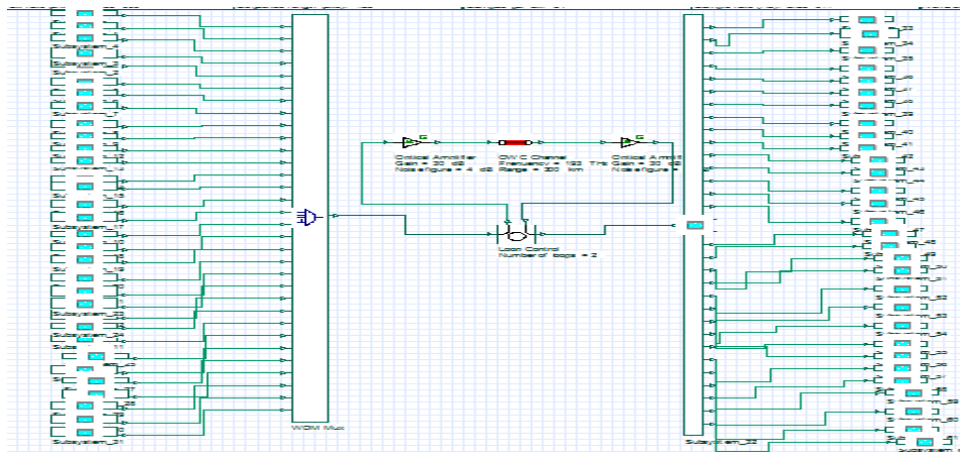

Fig. 4. Main Layout of Proposed model

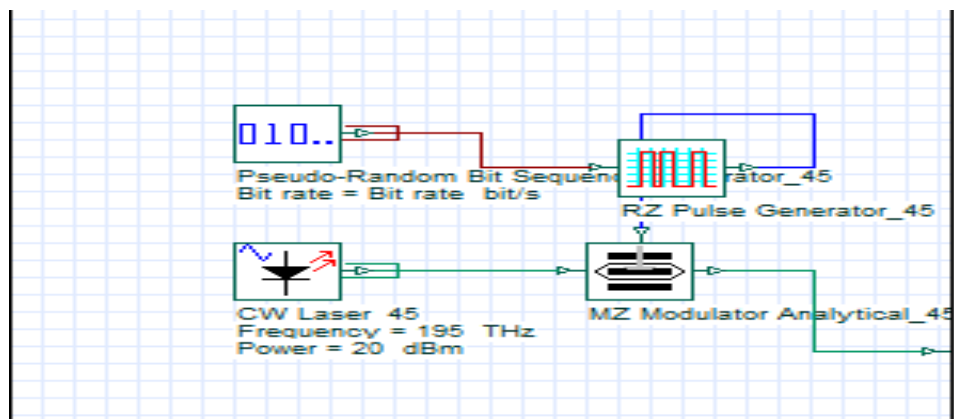

Fig. 5: Subsystem-1(Transmitter Section)

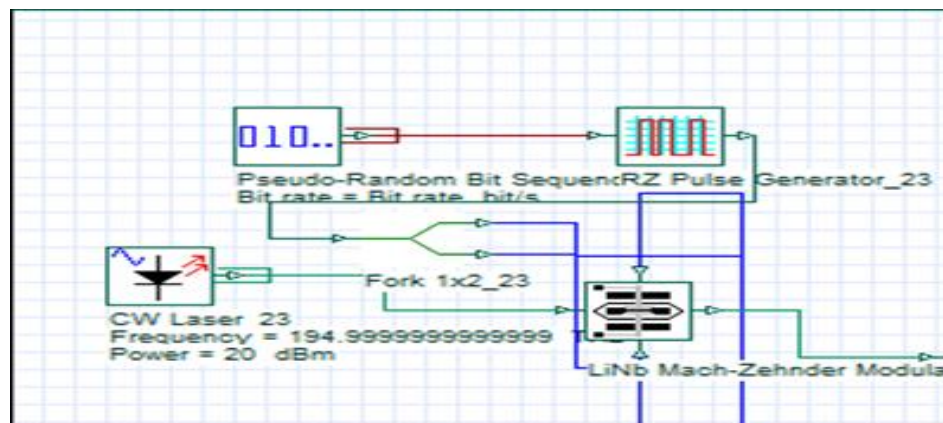

Fig. 6. : Subsystem-2 (Transmitter Section)

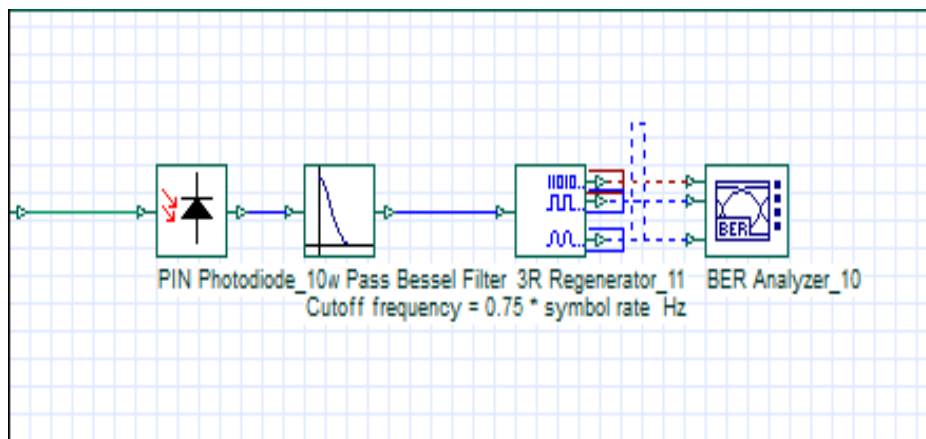

Fig. 7: Subsystem-3 (Receiver Section)

4. RESULT AND PERFORMANCE ANALYSIS :

a. Biterror rate (BER) eye diagram at bit rates 5Gbps, 7Gbps, 9Gbps, 10Gbps at different frequencies for distance=600km using MZ and LiNb MZ modulator.

From the output obtained it is evident that the BER is proportional to bit rate. If we increase bit rate BER also increases. Hence the frequency decreases. So we can end up with the fact that, if we increase the frequency BER decreases accordingly bit rate.

The following figure shows that for the lower value of frequency(193.0-196.0)nm at different bit rates gives out high Q-factor for MZ modulator and low Q-factor for LiNb modulator.

Mz Modulator Output At 5Gbps-

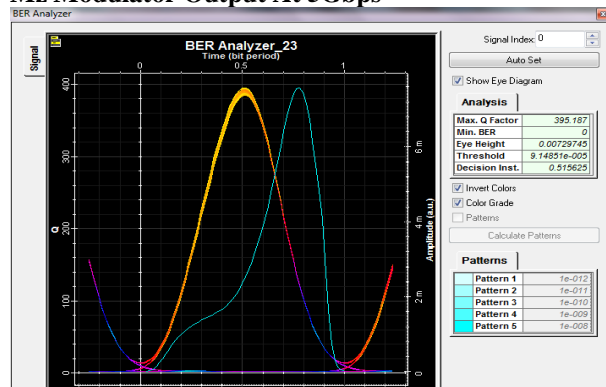

LiNb Mz Modulator At 5Gbps-

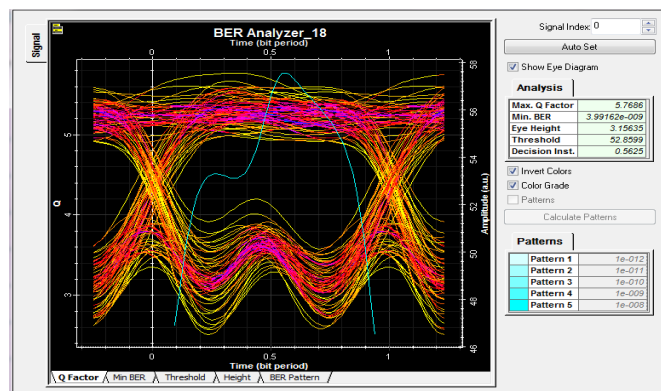

Mz Modulator Output At 7Gbps-

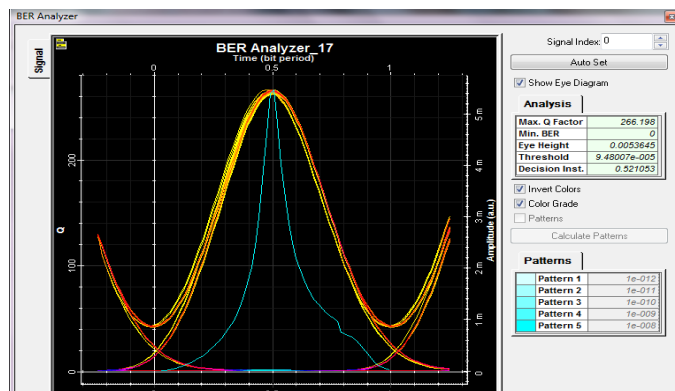

LiNb Mz Modulator At 7Gbps-

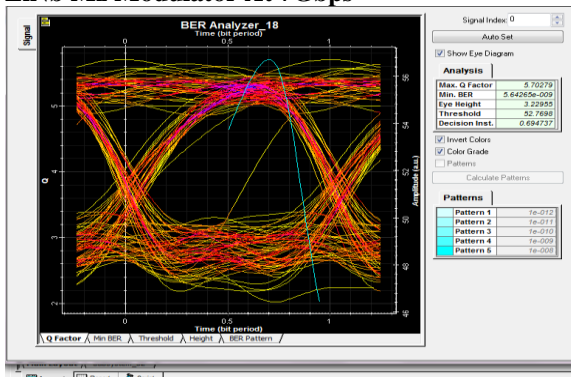

LiNb Mz Modulator At 10Gbps-

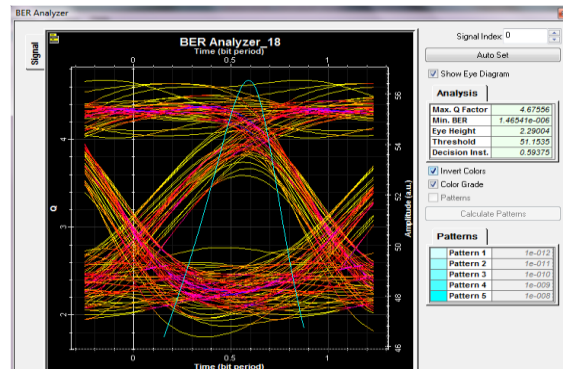

Mz Modulator Output At 9Gbps-

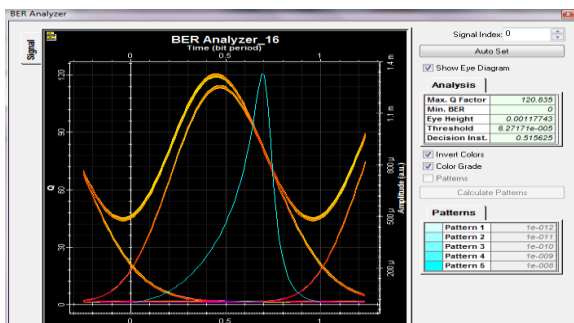

b. Performance Analysis By Considering Q-Factor At Different Frequencies And Different Bit Rates:

An isowc system is designed and simulated by the help of optisystem (14.0) consisting of two satellites with the space difference of 600km exchanging external modulated data at the selected data rates as mentioned earlier through optical wireless channels at different frequencies by using two different modulators separately i.e MZ and LiNb MZ modulators. Thus from the performance analysis between the modulators is being compared by considering Q-factor as shown in table-2 and table-3.

LiNb Mz Modulator At 9Gbps-

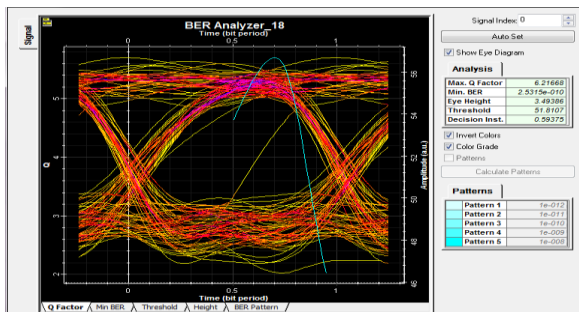

BIT RATE	5Gbps		7Gbps		9Gbps		10Gbps	
	FREQUEN CY	Q- FACTOR	FREQUENCY	Q- FACTOR	FREQUENCY	Q- FACTOR	FREQUENCY	Q- FACTOR
1	194.3	160.10	194.3	163.34	194.3	91	194.3	37.46
2	194.4	233.02	194.4	239.89	194.4	120.0	194.4	40.86
3	194.5	360.44	194.5	266.19	195.2	116.4	195.2	42.4
4	194.6	417.81	195.1	258.6	195.3	76.5	195.3	37
5	195.1	395.187	195.2	241.002	195.4	59	195.4	33.04

Table 2:Performance Analysis OF Mech-Zehnder modulator at different bitrate & at different frequency.

Mz Modulator Output At 10Gbps-

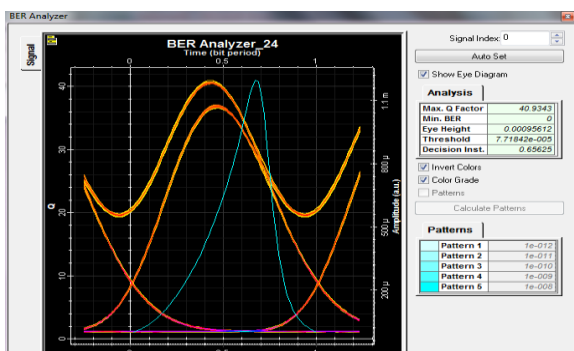

BIT RATE	5Gbps		7Gbps		9Gbps		10Gbps	
	FREQUEN CY	Q- FACTOR	FREQUENCY	Q- FACTOR	FREQUENCY	Q- FACTOR	FREQUENCY	Q- FACTOR
1	194.5	2.31	194.5	3.95	194.6	6.21	194.6	4.67
2	194.8	2.24	194.6	5.70	194.7	3.76	194.7	2.21
3	194.6	5.76	194.8	5.53	194.8	2.16	194.8	3.4
4	194	0	194	0	194	0	194	0

Table 3:Performance Analysis of LiNb Mech-Zehnder modulator at different bitrate & at different frequency.

5. CONCLUSION:

In this project we have designed and simulated an intersatellite ovc system using the optisystem(14.0) software with 32-channels over different bit rates and different frequencies to establish an intersatellite link between satellite to satellite at a higher altitude with a distance of 600km using the RZ modulation by keeping power and gain constant. Hence through the square root module we could see a better efficiency or performance achieved through the use of MZ modulators then the use of LiNb modulators, which further concludes that it is more reliable to use MZ modulators for increased number of channels at different data rates.

REFERENCES

- [1] Nareshkumar, "Enhanced performance analysis of inter-satellite optical-wireless communication (IsOWC) system", Sciencedirect journal, Optik volume 125, 2014, pp 1945-1949.
- [2] Z. Sodnik, B. Furch and H. Lutz, "Free-Space Laser Communication Activities in Europe: SILEX and beyond", Lasers and Electro-Optics Society (LEOS), IEEE, pp.78-79,2006.
- [3] A. H. Hashim, "Modeling and performance study of intersatellite optical wireless communication system", International Conference on Photonics (ICP), IEEE, pp.1-4, 2010.
- [4] Vishal Sharma and Naresh Kumar, "Modeling of 2.5 Gbps-inter-satellite optical wireless communications (IsOWC) system", sciencedirect journal, Optik xxx (2013).
- [5] "Chirp Signals". dspguide.com. Retrieved 2014-12-03.
- [6] Zehnder, Ludwig (1891). "Ein neuer Interferenzrefraktor".*Zeitschrift für Instrumentenkunde*. 11: 275-285.
- [7] Mach, Ludwig (1892). "Ueber einen Interferenzrefraktor".*Zeitschrift für Instrumentenkunde*. 12: 89-93.
- [8] M. A. Krainak, "Inter-satellite communications optoelectronics research at the Goddard Space Flight Center", Aerospace and Electro-system Magazine, IEEE, vol. 7, pp.44-47,1992.
- [9] Winzer,p.j., Pfennigbeuer,M., Strasser, M.M, Leeb,W.R,(2001),J. Light Wave Technol. 19(9)."Optimum filter bandwidth for optically pre-amplifier NRZ receivers", pp.1263-1273.
- [10] C. C. Chen and C. S. Gardner, "Impact of random pointing and tracking errors on the design of coherent and incoherent optical inter-satellite communication links", IEEE Transactions on Communication, vol. 37, pp: 252-260, 1989.