

Multiplied remote signal monitoring interface for process control using RS-485

Joshi Vilas R.

*Lecturer, S.B.PATIL COLLEGE OF ENGINEERING, Pune-Solapur highway, Tal Indapur, dist Pune (M.S.), India
Mobile no: 9765755771
joshivilas131071@gmail.com*

Abstract - Embedded controllers are often the heart of industrial and process control systems. Embedded systems are the brains of today's most digital and industrial control systems. In system where more than one processor is incorporated products that might exploit this feature include data terminal which receive updates from a control system, sensor which are interfaced by a monitoring station and multi-axis robots with each axis under the control of its own programmable AVR microcontroller along with reduced cost is auctioned in the project work. The microcontroller device and provinces simplified operating environment to the user. These enhance the capacities of general purpose embedded controller and provide a system For implementation of any industrial control application.

Keywords - phototransistor optocouplers carries digital data, advanced virtual RISC microcontroller, sugar cube relay, ULN 2004 relay driver and finally RS 485 transceiver.

1. INTRODUCTION

Data transportation is today a natural part of modern industrial automation process. More users appreciate the lined of security, suitability and economic efficiency offered by embedded system, embedded systems are the brains of today's most digital industrial control system. In system where more than one processor is incorporated, the needs for multiprocessor communication often arise.

The purpose of a multiplied process signal using RS 485 networking is discussion of a simplified prototype of industrial multiprocessor communication system using At mega 32 AVR microcontroller, via serial contraction RS 485 control. The operation of two micro controls in master – slave configuration is electorate.

The communication protocol developed in this project may be extended to meet the data transfer requirements in an industrial setting. In an industrial setting where there are to be two or more interrelated processing systems, the need for multiprocessor communications is indispensable. The microcontrollers may communicate via serial or parallel mode. Serial communication can be accomplished via many protocols e.g. RS 232 RS 422, & RS. 485. among them, RS. 485 is the most superior in terms of its distance range & the minimum number of communicating processors supported. 8/bit AVR microcontrollers are widely used mainly because are simpler and easier to use than 16-bit or 32-bit

microcontrollers and also due to their low cost among them, Motorola 68 HC11, microchip PIC family, and the industry standard 8051 are prevalent. To interface these devices to the outside world, input and output devices, like keypad, and LCD or LED'S respectively are generally used. In this project the serial RS-485 made of communication using ATmega 32 is the main concern.

I have used one slave and a master controller with sugar cube relay and photo transistor optocouplers and ULN 2004 relay driver IC and two unique board with suppurates power supply. The serial communication is performed via RS-485 standard.

The RS-485 is a serial communication protocol that uses balanced / differential voltage signals for transmission rather than ground referenced signals as is in case of RS-232; RS-485 is similar to RS-422 with differences in that unlined RS-422, it support multiple drivers and recovers. It is used for multipoint communications more devices may be connected to a single cable most RS-485 systems use master / slave architecture, where each slave unit has wits unique address and responds only to packets addressed to this unit. The common master generates these packets.

An RS-485 link can extend as for as 1200 (meters) and can transfer data at up to 5 MBPS data rate. The ADM 485 is a differential line transceiver suitable for high speed bidirectional data communication on multipoint bus transmission lines.

Two wires (usually a twisted pair) carry the signal voltage and it's inverse. The receiver detects the difference between the two, because most noise that couples into the wires is common to both wires, it cancels out.

2. BACKGROUND PROBLEM

Problems associated with data transportation in industrial environment

- 1) It requires the number of wires to carry important control signal from process and the control panel.
- 2) To expand the available lines for data carrying purpose.
- 3) In telecommunication industries this MULTIPLIED PROCESS CONTROL SIGNALS RS 485 NETWORKING is useful to enhance more number of devices to the system.
- 4) In process industry corrective action takes less time with this PCSU RS- 485 networking.

3. WORKING PRINCIPAL

Embedded systems or the brains of today's most digital and industrial control systems. In systems where more than one processor is incorporated, the need for multiprocessor communication often arises. products that might exploit this feature include data terminals which receive updates from a central control system, sensor systems which are interrogated by a monitoring station and multi-axis robots with each axis under the control of it' own processor to a name a few. In this project, we have discussed a simplified prototype of industrial multiprocessor communication systems using AVR AT mega 32 microcontrollers, via serial communication Rs. 485 protocol.

The communication protocol developed in this project may be extended to meet the data transfer requirement in an industrial setting. There has been a great shift of trend to words fabrication and industrial use of embedded systems during the last three decades owing to manifold increase in their applications. In on industrial setting where there are to be two or more interrelated processing systems, the need for multiprocessor communications is indispensable.

The microprocessors or microcontrollers may communicate via serial or parallel mode. Serial communication can be accomplished via many protocols eg. Rs. 232, Rs. 485, and Rs. 485 among them, Rs. 485 is the most superior in terms of its distance range and the minimum number of communicating processors supported. 8-bit microcontrollers are widely used mainly because they are simpler and easier to use than 16-bit or 32-bit microcontrollers and also due to their low cost. Among them, Motorola 68 HC1, microchip PIC family and the industry standard AT mega 32 are prevalent. To interface these devices to the outside world, input and output devices, LED's are generally used.

In this project the serial Rs-485 mode of communication using AT mega 32 is the main concern, with on emphasis on interfacing it with LED and relay we have used one slave and a master controller with on LED and relay. The Serial communication is performed via Rs-485 standard.

The Rs-485 is a serial communication protocol that uses balanced / differential voltage signals for transmission, rather

than ground referenced signals arises in case of Rs 232, Rs-485 is similar to Rs-422 with the difference in that Rs- 422 it supports multiply drivers and receivers.

It is used for multipoint communications: more devices may be connected to a single signal cable. Most Rs-485 systems use Master / slave architecture, where each slave unit has its unique address and responds only to packets addressed to unit. The common master generates.

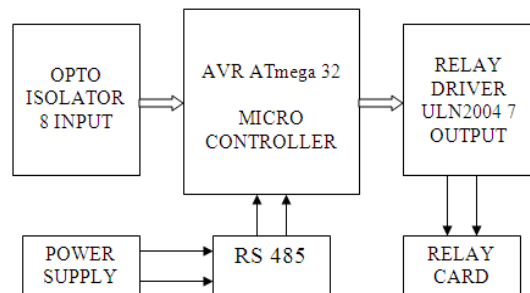

Fig. 3.1 : Block Diagram.

In accordance with the above block diagram. AVR AT mega 32 microcontrollers can be used in the circuit. Part B is used for input through optoisolater, Port D for MAX 485 output. Port C for output Relay driver. If user wants to change these port assignments, he can do this in hardware and simply make very few changes in initialization port of software to use this hardware.

3.1 Program flow chart :

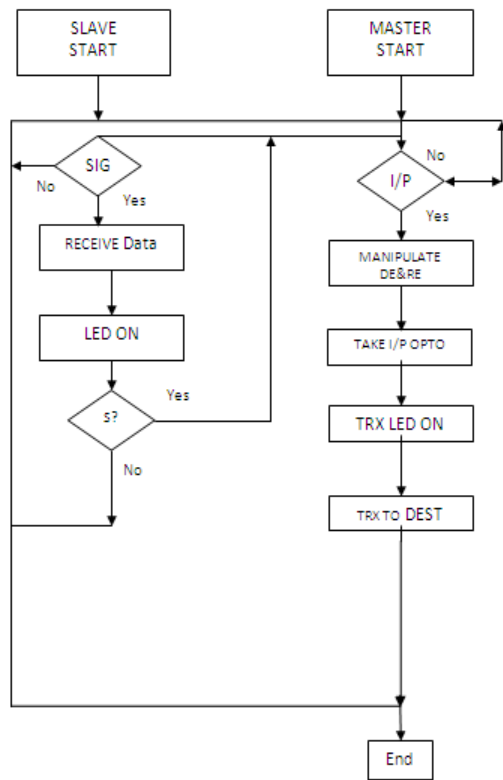

Figure 3.8: Flow Chart

Flow chart explains the simple programming instruction execution. Master checks the input signal if it is present manipulate RS-485 direction pin DE & RE take input through optocouplur and passes it towards desired destination. Slave checks the input is present then it acts as a master and again repeats the process for desired output.

3.2 Hardware :

Table 1. Hardware Components

Component	Description
Connector J1	MKDSN Industry Standard Connector.
RL1 To RL7	Single pole 10 A Power Relay (Sugar Cube)
D1 to D7	SMD Freewheeling Diodes.
R1 to R27	SMD type resistors.
L1 to L9	LED

ISO9 to ISO16	4 pin Phototransistor Optocouplers.
RA1	Resistor SIP9.
U1	AT mega 32 AVR microcontroller
U9	LM 317, 5 V Voltage Regulator.
U8	ULN 2004 Relay driver
U7	ADM 485 IC
J2	For Programming JIA4 Connector.
Y1	Master / Slave Selector switch.
J3	Power Connector.
J4	Jumper to connect next AVR.
C34	10 uf Capacitor.
SLOT on PCB	Routing to avoid stray capacitor

Specification of the System

- Digital Input: 8 optoisolated inputs (5V to 24 VDC) Inputs can be potential inputs or potential free contacts.
- Digital Outputs: 7 open collector outputs which user can configure as per the requirements of the application.
- EEPROM for Program Storage: 1024 Bytes.
- Data memory (RAM): 32 K bytes + SRAM.
- On delay and off delay timers with different time settings.
- TWO LED's for transmitter and receiver indication and 7 LED for output status of system.
- On – board regulator LM 317 to generate -5 VDC.
- Selector switches to select communication mode form master to slave or slave to master mode.

4. SYSTEM ANALYSIS

Comparison between results obtained by analytical analysis and experimental analysis

Table 2. Result obtained by analytical analysis and Experimental analysis.

Sr. No.	Performance Parameter	Results From Analytical Analysis	Results From Experimental
1	Cost of the system	Very low	Low
2	Adaptability / flexibility	Very high	Very low
3	Programmability	Very simple	Complex
4	User interface	Very friendly	Very friendly
5	Universality	Very high	Very low
6	Skilfulness required	Very low	Very high

Justification of Analytical analysis and Experimental analysis.

The difference between system developed and dedicated embedded controller given above are the main advantages of the system. On account of these the system can be proved efficient in all aspects. The most beneficial point of difference is the adaptability of the system to variety of applications. A user of the application though not skilful in microcontroller programming but can use system is very user friendly.

The work was done with the main aim to combine the advantages of low cost and reduced size of embedded system and the advantage of very efficient and simple C programmability to give embedded control system.

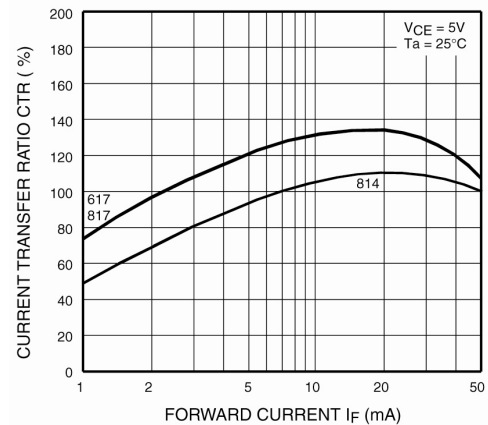

Fig. Current transfer ratio Vs Forward current for optocoupler as input device.

5. APPLICATIONS

1. Automatic door control system.
2. Commercial Lighting.
3. Ventilation System.
4. Factory door Control system.
5. Air conditioning System.
6. In telecommunication field.
7. Control controlling and monitoring of several factory gates.
8. Machine Control.
9. Shop window fighting.
10. Packaging and martial handling.
11. Water level control in greenhouse.

6. FUTURE SCOPE

There is no limit to future scope in the area of automation, telecommunication, process control industry Industrial automation is no longer limited by the walls of production facility. More and more automation is being bundled via remote communication, whether it's from the office or from the comfort of your own home.

The system can be up graded to incorporate analog inputs and analog outputs. This will increase its area of application to more number of applications.

7. CONCLUSIONS

Multiplied Remote Signal Monitoring Interface for process control using RS- 485 are an integral part of modern industrial environments as today communication between processor are of much more important than ever. The hardware developed is a simplified prototype of the communication models used in industrial environments with master controller representing the control room from where instruction and commands and sent to different sections of the industrial setting and slaves mimicking the role of locations where these commands are sent to be exited more often than

not such destinations are also capable to sent latest data to the control room eg. sensors as was the case with slave. The communication protocol used is a very simplified are, but given insight into how such communications are accomplished in high-tech industrial environments. Moreover, Rs-485 in perfect for transferring small blocks of information over long distances and the RS- 485 standard is found to be extremely flexible.

Universal Embedded Control System with Multiplied Remote Signal Monitoring Interface for process control using RS-485 operating system software for AT mega 32 based embedded system boards has been developed.

Operating system software can be lauded into any general purpose embedded system board based on AT mega 32 micro controller. This provides the facility of bi-directional communication with half duplex i.e. Master to slave and slave to master desired data can be sent on two wire cable.

REFERENCES

- [1] M.Mazidi "The 8051 Microcontroller and Embedded System" 2nd edition pp 83 to 91, 236 to 242.
- [2] Www//data sheet.com/ aamega32 Assessing date 1 April 2010.
- [3] Han-Way Huang (2000), using the MCS-51 Microcontroller, Oxford University Press.
- [4] Stewart, J.W. (1993), The 8051 Microcontroller – Hardware, Software and Interfacing Prentice Hall.
- [5] Tabak, D. (1995), Advanced Microprocessors, McGraw Hill.
- [6] Kamal, R (1995), Electronics Practical – Interface and Communication Electronics, Scholar Pub ., Indore.
- [7] Mukhopadhyay, A.K. (1996), Text Book on Microprocessor Based Laboratory Experiments and Project, Wheeler.
- [8] 8. Mukhopadhyay A.K. (1995) , Microprocessor , Microcomputer and their Applications, Narosa.
- [9] Tabak, D. (1990), Multiprocessors Prentice Hall.
- [10] Lipovski, G.L. (1988), single – and Multi-chip Microcomputer Interfacing Prentice Hall.
- [11] Stallings, W. (1987), Computer organization and Architecture, Macmillan.